

DICHTOMATIK RADIAL SHAFT SEALS



The information contained herein is considered to be reliable, but no assurances, warrants or guarantees whatsoever, of any kind, are provided with regard to its correctness or suitability for any purpose.

The information reproduced herein is based on laboratory tests and is not necessarily indicative of the performance of the end product. Complete testing and the performance of the end product are the users' responsibility.

CONTENTS

COMPANY	4
Industry-specific and customized service concepts	6
Product portfolio of the Dichtomatik brand	7
CONSTRUCTION RADIAL SHAFT SEALS	8
OVERVIEW RADIAL SHAFT SEALS	10
MATERIALS	12
Standard materials	14
Special materials	15
Materials for tension springs	15
Materials for stiffening rings	15
SEALING FUNCTIONS	16
Sealing to the housing bore	17
Dynamic sealing mechanism	21
OPERATING CONDITIONS	24
Temperature and pressure	25
Media to be sealed	27
INSTALLATION SPACE AND DESIGN RECOMMENDATIONS	28
About the shaft	29
Housing bore	32
INSTALLATION	34
QUALITY ASSURANCE	36
SHAFT REPAIR SLEEVES	38



COMPANY

The Freudenberg Group was founded in 1849 and is still owned by the approximately 300 descendants of the company founder. The resulting financial stability and social awareness are decisive success factors that create trust. Today, Freudenberg is a global, broadly diversified group of companies divided into Business Groups that operate in a wide variety of sectors. The company has always been considered an innovation and technology leader, from Vileda® brand household products to technically complex sealing solutions.

Freudenberg Sealing Technologies is the largest business group in the Freudenberg Group with some 13,500 employees and is part of the Seals and Vibration Control Technology business area. As a technology expert and global market leader for sealing technology, Freudenberg Sealing Technologies is a reliable supplier and professional development and service partner to industry. The company acts as a trusted partner to its customers, for example in the automotive industry, civil aviation, mechanical engineering and shipbuilding, the food and pharmaceutical industries, and the agricultural and construction machinery industries.

Based on their knowledge of engineering and the market acquired over many years, the sealing experts find the right solution for all sealing requirements. Worldwide production and warehouse locations as well as a network of strong Distribution partners enable outstanding product availability. In addition, customers benefit from an extensive portfolio of product-related, logistics and online services.

Freudenberg Sealing Technologies has a broad, customer-oriented product portfolio of premium Freudenberg

brand products for all applications – from customized individual solutions to complete sealing packages.

In addition, Dichtomatik brand products are ideal for several moderately demanding applications in general industry. The wide range of products is characterized by a very good price-performance ratio. Manufactured by certified external suppliers, the sealing products and solutions reliably meet common industrial market quality standards. Additional services such as general technical support round off the range.

Freudenberg Sealing Technologies offers technical services such as the preparation of drawings, radial force measurements, comprehensive quality and material documentation as well as material modifications and testing to ensure that all seals function reliably even in individual applications. Furthermore, local availability ensures short distances and fast response times to best serve customer needs.

FREUDENBERG SEALING TECHNOLOGIES SERVES THE ENTIRE SEALING MARKET WITH THIS COMPLEMENTARY PRODUCT PORTFOLIO AND THUS MEETS ALL MARKET REQUIREMENTS – QUICKLY, RELIABLY AND FROM A SINGLE SOURCE

INDUSTRY-SPECIFIC AND CUSTOMIZED SERVICE CONCEPTS

ONLINE ORDERING PLATFORM EASY

The EASY online ordering platform enables easy order processing, as well as price, delivery time and stock queries around the clock. Besides detailed product information, installation space and cross-sectional drawings are available for download. The EASY Business Connector is used to transfer your orders directly to your SAP system. This ensures that you are always up to date on the status of your order. Register today if you do not yet have an EASY account.



APPLICATION KNOW-HOW

Dichtomatik products are also certified for special applications, e.g. in the food industry. This enables us to find the right solution for every application. To ensure that seals function reliably even in individual applications, our team of experts offers technical services such as drawing preparation, radial force measurements, comprehensive quality and material documentation as well as material modifications and testing. Customer-specific sealing solutions, kitting and single packaging are just some of the other services that can be offered (offerings vary by country).



LOGISTICAL SERVICES AND QUALITY STANDARDS

The 6,500 m² warehouse in Hamburg, which functions as a European logistics hub, has just one objective: delivering Dichtomatik's uniquely high number of warehoused items as quickly as possible to the locations they are needed at. In addition to the roughly 60,000 standard dimensions, around 15,000 customer-specific seals are available from stock. Additional warehouse locations around the world support the supply chain to ensure rapid availability for our customers.



Special logistics solutions, such as Kanban or vendor-managed inventory, quality testing and simplified customs processes due to certifications, simplify order processing. The location in Hamburg (incl. the warehouse) is certified according to DIN ISO 9001 and DIN ISO 14001, thus guaranteeing standardized processes in the quality and environmental management system. In addition, current processes are

analyzed and improved in regular Kaizen workshops. Furthermore, warehouse processes are supported by new technologies. For example, the forklifts have been converted into mobile workstations by using tablets and portable printers, and innovative glove scanners are used for scanning processes. Our other warehouses also meet the highest quality requirements and are part of regular certifications.

PRODUCT PORTFOLIO OF THE DICHTOMATIK BRAND

STATIC APPLICATIONS



The whole range of static seals – O-rings, cords, x-rings, cover seals, bolt seals, flange and profile seals, etc. is available in a large number of dimensions including metric, inch and other international standards. The variety of materials, also with application-specific certifications, leaves nothing to be desired.

ROTATING MOVEMENTS



Rotary shaft seals are available in the standard versions with and without protective lips and in the materials NBR and FKM. In addition to the standard designs, the product range also includes special designs of rotary shaft seals, axial seals, shaft sleeves and radial seals for rotary and swivel movements.

TRANSLATIONAL MOVEMENTS



Piston seals, rod seals, wipers, guide belts and rings for hydraulics are available from stock in countless standard dimensions in the materials including NBR, PTFE, TPU, hard fabric and NBR fabric-reinforced. Application-specific modifications of the design or material can also be realized.

IMPORTANT NOTE

Dichtomatik brand products meet common industrial market quality standards and are therefore suitable for moderately demanding and non-safety-critical applications. Dichtomatik products are not approved for use in the automotive industry, aerospace and other safety-critical applications. An overview of complementary premium sealing solutions can be found at www.fst.com.



e-Catalog



CONSTRUCTION RADIAL SHAFT SEALS

Radial shaft seals are used to seal rotating machine elements against media from inside the system and contaminants from the outside. Selecting the right seal depends on various operating conditions, such as the circumferential speed of the shaft, the operating temperature, the operating medium, the pressure and the ambient conditions on the side facing away from the medium.

Our Radial shaft seals in the standard design are manufactured accordance to DIN 3760 and consist of an elastomer part, a metal stiffening ring and a spring. The standard design is available with an additional protective lip to the bottom side on an optional basis.

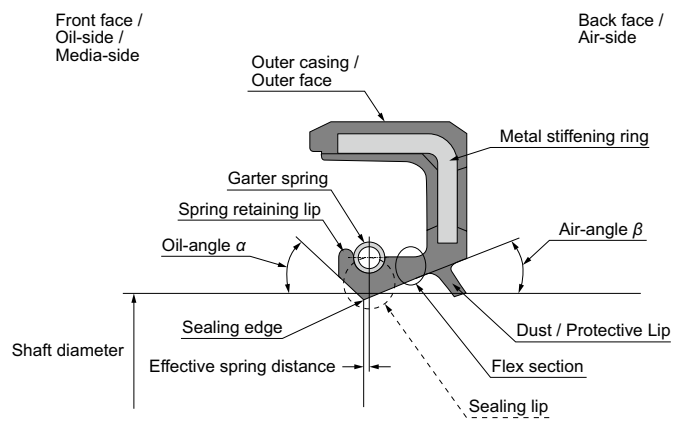

COMMON STANDARD DESIGNS*

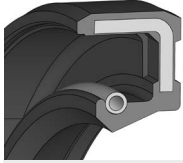
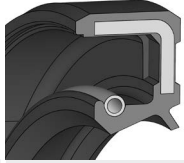
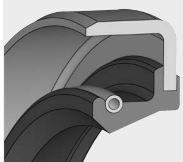
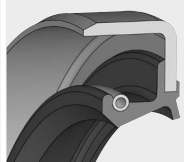
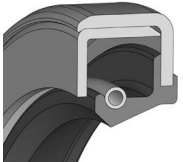
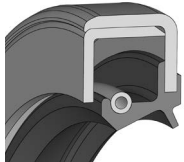
Profile	Design	Profile	Design	Nomenclature
	WA		WAS	W - Shaft seal A - Elastomer outer covering S - Protective lip
	WB		WBS	B - Metal outer surface
	WC		WCS	C - Metallic outer surface with additional stiffening ring

* Additional profiles can be found in the e-Catalog or on page 11



e-Catalog

AREAS OF APPLICATION

Radial shaft seals are used to seal rotating machine elements such as shafts, hubs and axles in a wide range of industries:

You'll find detailed information on our products and the available certifications and conformity tests in our e-Catalog.



DRIVE TECHNOLOGY, E.G. GEAR CONSTRUCTION



AGRICULTURAL AND CONSTRUCTION INDUSTRY



ELECTRIC MOTORS, INTERNAL COMBUSTION ENGINES



HOUSEHOLD AND INDUSTRIAL WASHING MACHINES ("WHITE INDUSTRY")







PUMPS



WIND POWER INDUSTRY, SHIPBUILDING AND ROLLING MILLS

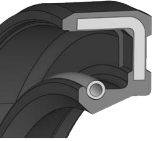

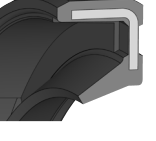
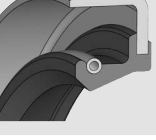
OVERVIEW RADIAL SHAFT SEALS

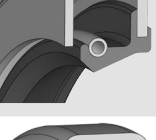
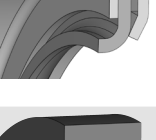
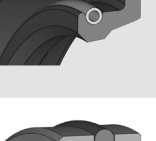
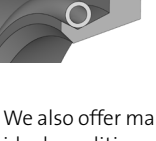
Profile	Design	Material	Hardness [Shore A]	Temperature [°C]	Max. Speed [m/s]	Max. Pressure [MPa (bar)]	Application
	WA	NBR	70 75	-40 to +80 (briefly +100)	10	0,05 (0,5)	<ul style="list-style-type: none"> • good static sealing with low-viscosity or gaseous media • good resistance to many mineral oils and greases • FKM: broad resistance to chemicals and solvents
		FKM	70 80	-25 to +150	34		
	WAY	NBR	80	-40 to +80 (briefly +100)	10	1 (10)	<ul style="list-style-type: none"> • for use with compressive loads • good resistance to mineral oils and greases • FKM: broad resistance to chemicals and solvents
		FKM	80	-25 to +150	10		
	WAO	NBR	70	-40 to +80 (briefly +100)	6	0 (0)	<ul style="list-style-type: none"> • suitable for sealing against grease • good static sealing with low-viscosity or gaseous media
		FKM	80	-25 to +150	8		
	WB	NBR	70	-40 to +80 (briefly +100)	10	0,05 (0,5)	<ul style="list-style-type: none"> • good resistance to various mineral oils and greases • tight and precise fit
	WBO	NBR	70	-40 to +80 (briefly +100)	6	0 (0)	<ul style="list-style-type: none"> • good static sealing with low-viscosity or gaseous media • suitable for sealing against grease
		FKM	80	-25 to +150	8		
	WC	NBR	70	-40 to +80 (briefly +100)	10	0,05 (0,5)	<ul style="list-style-type: none"> • good resistance to various mineral oils and greases • higher stiffness, tighter and more precise fit due to an additional stiffening ring
		FKM	80	-25 to +150	34		
	WCP	PTFE		-90 to +250	25	1 (10)	<ul style="list-style-type: none"> • low coefficient of friction • good choice for dry running and lack of lubrication • broad chemical resistance
	WE 5/6/7	NBR	80	-30 to +80 (briefly +100)	20	0,05 (0,5)	<ul style="list-style-type: none"> • good resistance to various mineral oils and greases • FKM: broad resistance to chemicals and solvents
		FKM	80	-20 to +180	25		
	WEPO	PTFE		Dependent upon O-ring material	15	1 (10)	<ul style="list-style-type: none"> • broad chemical resistance to nearly all aggressive media

We also offer many of the profiles with an additional protective lip. The values listed in the above table define the operational limits under ideal conditions and should not be implemented simultaneously. The above data is dependent upon the max. speed, shaft diameter, material, temperature, pressure, medium as well as various additional factors. It is therefore recommended to initially test run the shaft seal in the application.



MATERIALS

Various standard and special materials are available for Dichtomatik brand radial shaft seals, depending on the model and the area of application. The raw material for elastomers is rubber, which can be obtained as natural rubber, but is mainly produced today as synthetic rubber in the chemical industry. Elastomers are distinguished by the underlying base polymer. The final material is produced by mixing the base polymer with appropriate fillers, plasticizers, processing aids, vulcanizing agents, accelerators and

other additives. This process makes it possible to achieve the desired material properties and thus to offer standard materials for a wide range of uses as well as special compounds for very specific applications. The elastomer materials are labeled based on the abbreviated designations of DIN ISO 1629 and ASTM D 1418.

ABBREVIATIONS OF THE SEALING MATERIALS FOR RADIAL SHAFT SEALS

Chemical name	Abbreviation
	DIN ISO 1629 / ASTM D 1418
Acrylonitrile butadiene rubber	NBR
Hydrogenated acrylonitrile butadiene rubber	HNBR
Fluorine rubber	FKM
Ethylene propylene diene rubber	EPDM
Silicone rubber	VMQ
Acrylic rubber	ACM
	DIN EN ISO 1043-1 / ASTM D 1600
Polytetrafluoroethylene	PTFE

STANDARD MATERIALS

For the standard portfolio, a wide range of radial shaft seals are available in two varieties of elastomer and two types of PTFE materials.

STANDARD ELASTOMER MATERIALS FOR RADIAL SHAFT SEALS

Base elastomer	DIN ISO 1629	Hardness [Shore A]	Color	Temperature [°C]*
Acrylonitrile butadiene rubber	NBR	70	black	-40 to +80, +100 for a brief time
Fluorine rubber	FKM	80	brown	-25 to +150

*Temperature data applies to the area of the sealing lip. Operating conditions such as the medium, fresh oil supply, heat dissipation and friction can influence the temperature at the sealing lip.

STANDARD PTFE MATERIALS FOR RADIAL SHAFT SEALS FOR THE WEPO AND WCP PROFILES

Base polymer	DIN EN ISO 1043-1	Fillers	Hardness [Shore D]	Temperature [°C]	Design
Polytetrafluoroethylene	PTFE	Charcoal/graphite	62	Depending on the selected OR material	WEPO
Polytetrafluoroethylene	PTFE	Carbon fiber	61	-90 to +250	WCP

NBR – ACRYLONITRILE-BUTADIENE RUBBER

Radial shaft seals made of NBR are known for their high abrasion resistance and good resistance to common mineral oil-based lubricating oils and greases. However, NBR resistance to ozone, weathering and aging is low.

PTFE – POLYTETRAFLUOROETHYLENE

PTFE offers virtually universal resistance to chemicals, has a broad thermal application range (-90 °C to +250 °C), an extremely low coefficient of friction and very high resistance to ozone, weathering and aging.

FKM – FLUORORUBBER

FKM materials are known for their very high temperature and chemical resistance. They age well, are resistant to ozone and have very low gas permeability making them well suited for vacuum applications. By contrast, FKM is not resistant to hot water, steam, polar solvents, glycol-based brake fluids and low-molecular organic acids.

In addition to the standard materials described, we can provide various special materials for special applications on request. Other material variants in other degrees of hardness and colors are also available on request.

MATERIALS FOR TENSION SPRING

STANDARD MATERIAL

The standard tension springs integrated into the radial shaft seals are made of unalloyed spring steel according to DIN EN 10270-1.

SPECIAL MATERIAL

On request, we also offer springs in stainless and acid-resistant steel 1.4301 (AISI 304).

MATERIALS FOR STIFFENING RINGS

STANDARD MATERIAL

We offer stiffening rings made of unalloyed steel according to DIN EN 10139.

SPECIAL MATERIAL

On request, we can also offer the stiffening rings in stainless and acid-resistant steel 1.4301 (AISI 304).



SEALING FUNCTIONS

A RADIAL SHAFT SEAL ESSENTIALLY HAS TWO TASKS TO FULFILL:

- 1.** Sealing between the outer diameter and the housing bore, taking various influencing variables into account such as temperature, pressure, vibrations, the material the housing is made of, the material of the shaft seal outer diameter, etc.
- 2.** Sealing to the shaft, where many influencing variables must be taken into account, such as speed/the circumferential speed of the shaft, the temperature, the application, the medium to be sealed, the pressure, the installation situation, etc.

In order to fulfill these tasks, the housing bore and the shaft have to comply with distinct specifications.

SEALING TO THE HOUSING BORE

To ensure reliable sealing against a wide variety of media when installed, an overlap (interference fit) of the shaft seal ring to the housing bore must be guaranteed under all operating conditions. Both the manufacturing tolerances of the housing bore and its expansion, e.g. due to the rise in temperature during operation, must be accounted for.

In addition, care must be taken that the roughness of the housing bore is not too great to avoid “creep” of the sealed medium through this rough structure.

If the roughness is too low, this can vastly increase the assembly forces (especially in shaft seals with an elastomer outer covering), which can cause damage to the outer diameter.

This predetermined structure ensures a secure and tight fit to avoid large deviations of the fully encased shaft seals in the bore during operation.

To fulfil both requirements (sealing and secure fit), the following values should be applied which correspond to the limits specified in DIN 3670 and ISO 6194.

THE TABLE ONLY APPLIES IF THE HOUSING DIAMETERS ARE MANUFACTURED ACCORDING TO TOLERANCE CLASS IT H8

Nominal outside diameter [mm]	Press fit allowance for different shaft seal designs	
	Design WA (smooth elastomer outer covering) Values according to DIN 3760 and ISO 6194	Models WB, WC (metallic outer covering) Values according to ISO 6194
≤ 50	+ 0.30	+ 0.20
	+ 0.15	+ 0.08
> 50 - 80	+ 0.35	+ 0.23
	+ 0.20	+ 0.09
> 80 - 120	+ 0.35	+ 0.25
	+ 0.20	+ 0.10
> 120 - 180	+ 0.45	+ 0.28
	+ 0.25	+ 0.12
> 180 - 300	+ 0.45	+ 0.35
	+ 0.25	+ 0.15
> 300 – 500*	+ 0.55	+ 0.45
	+ 0.30	+ 0.20

* the value is 530 in ISO 6194

DESIGN OF THE OUTER SURFACES – INFLUENCE OF THE DIFFERENT DESIGNS

Radial shaft seals are typically offered with an elastomer outer covering or a metallic outer surface and are also available with an additional protective lip.

SMOOTH, ELASTOMER-COATED OUTER SURFACE: DESIGNS WA, WAS

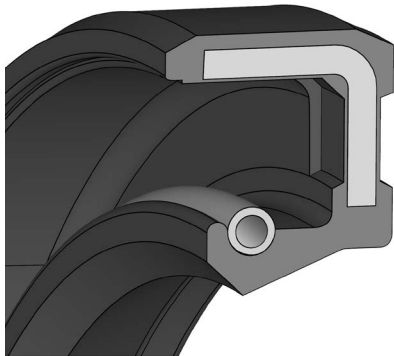

Advantages:

- good static sealing
- can be used for split housings, with possible edge breakage and/or butt offset
- use with light metal housings with high thermal expansion or with all housings that have a greater coefficient of expansion than steel
- use with low-viscosity or gaseous media
- use in pressure applications (within the limits of use)
- can seal larger surface roughnesses (within the standardized values)
- no fretting corrosion occurs
- if mounted and dismounted correctly, the housing bore will not be damaged

GROOVED, ELASTOMER-COATED OUTER SURFACE: DESIGNS WAK

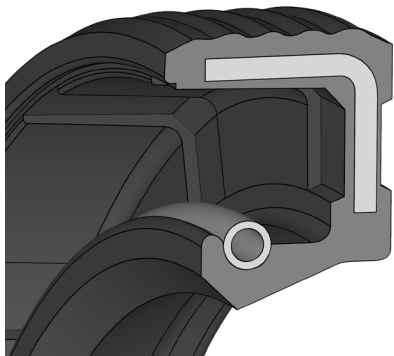

The elastomeric outer covering is grooved in the circumferential direction.

Advantages:

- easier assembly due to lower required press-fit force
- reliable static sealing, especially for housings with increased thermal expansion as the grooved, rubber-covered outer surface is designed with a higher interference fit allowance

METALLIC OUTER SURFACE: DESIGNS WB, WBS

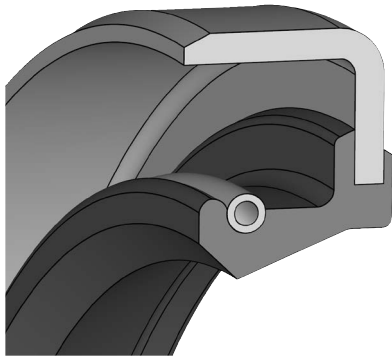

For WB and WBS Profile radial shaft seals, the metallic, smooth outer surface of the stiffening ring is ground, drawn or turned.

Advantages:

- precise (centric) and tight fit in the bore is ensured
- can be used for split housings, with the risk of possible edge breakage and/or butt offset

Disadvantages:

- the outer surface must be designed with a tighter interference fit allowance
- higher surface quality of the housing bore is required
- problematic with large thermal expansions of the housing, rough bore surfaces, pressure applications or very low-viscosity media

METALLIC OUTER SURFACE WITH A STIFFENING RING: DESIGNS WC, WCS

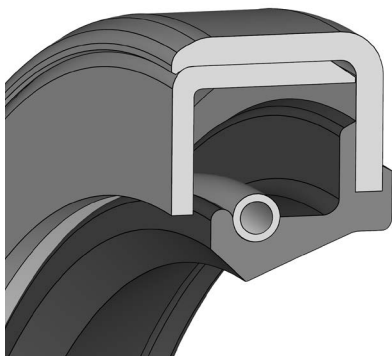

Type WC/WCS radial shaft seals have a smooth metallic outer surface like models WB/WBS with an additional metal stiffening ring. These profiles are used for particularly difficult installation conditions, rough operating conditions and larger dimensions. Model WC radial shaft seals have a higher rigidity than model WB radial shaft seals. Due to the additional stiffening ring, the WC/WCS designs are very insensitive to installation errors.

For advantages and disadvantages, see models WB/WBS

PARTIALLY ELASTOMER-COATED OUTER SURFACE: PROFILE WAB

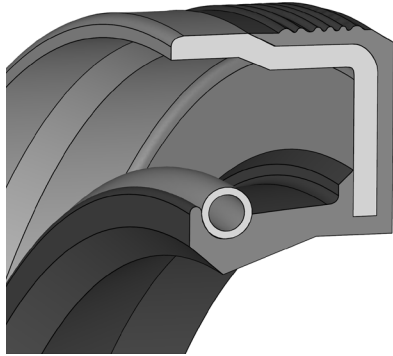

The so-called “half-shoulder model” is a special design that is not offered as standard. It combines the advantages of models WA (rubber-covered outer surface → good sealing effect) and WB (metallic outer surface → a tight fit).

STATIC SEAL TO THE SHAFT

The seal to the shaft is generated due to the smaller diameter of the sealing lip in comparison to the shaft; the resulting overlap ensures that the sealing lip encloses the shaft with a specific force, known as the radial force. In addition, a screw tension spring is installed with a certain preload, which largely compensates for a reduction in the radial force due to aging of the elastomer material or wear. The total radial force (FR) is thus composed of the elastomer component (FE) and the spring component (FF). An Rz value of 4 µm is specified as the maximum roughness.

A static seal is thus achieved. The surface of the shaft shouldn't be too rough to prevent a medium from infiltrating the sealing lip via the rough surface structure of the shaft.

DYNAMIC SEAL TO THE SHAFT

Several factors must be taken into account for sealing during operation, i. e. when the shaft is rotating. To prevent the sealing lip from wearing during operation, it must be ensured that a light lubricating film is formed between the shaft and the sealing lip (the contact area). For this purpose, the shaft is machined so that a minimum roughness of 1 µm is achieved. This structure allows some oil to enter the contact area between the shaft and the sealing lip (capillary effect), thus preventing extreme wear due to permanent dry running. However, oil would then also reach the air side via this path and this must be prevented. How this works is described in the so-called distortion hypothesis.

DYNAMIC SEALING MECHANISM

SEALING EFFECT WITH A ROTATING SHAFT

Several conditions must be met to ensure that the contact area is lubricated during operation, but that no oil can migrate to the outside.

The geometry of the sealing lip must meet the following criteria when installed:

- the oil angle “ β ” of the sealing lip should be approximately $+45^\circ - +60^\circ$
- the air angle “ α ” should be significantly smaller

DESCRIPTIONS ON THE SHAFT SEALING RING

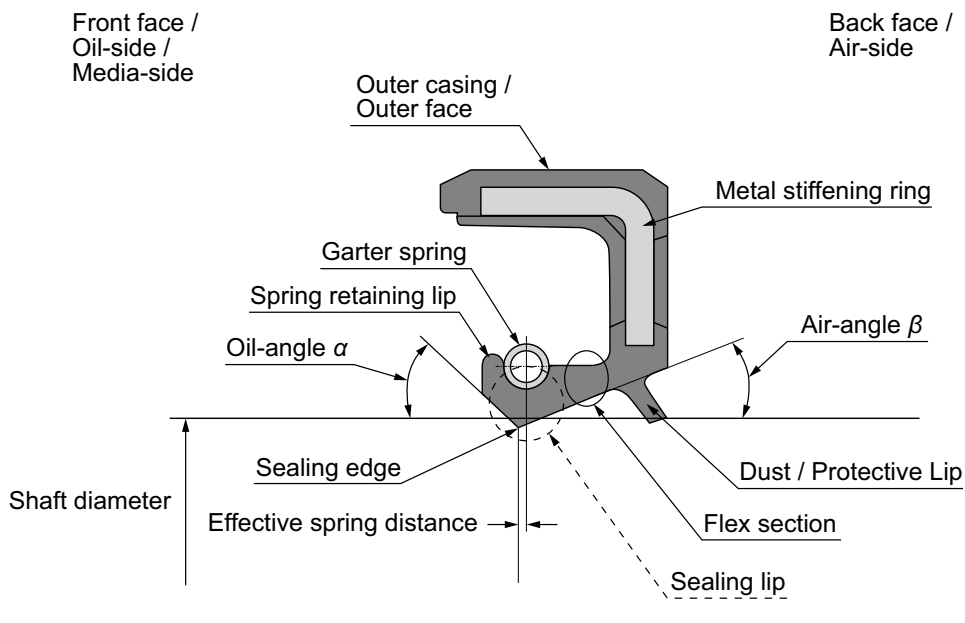

This special geometric design results in uneven pressure distribution in the contact area.

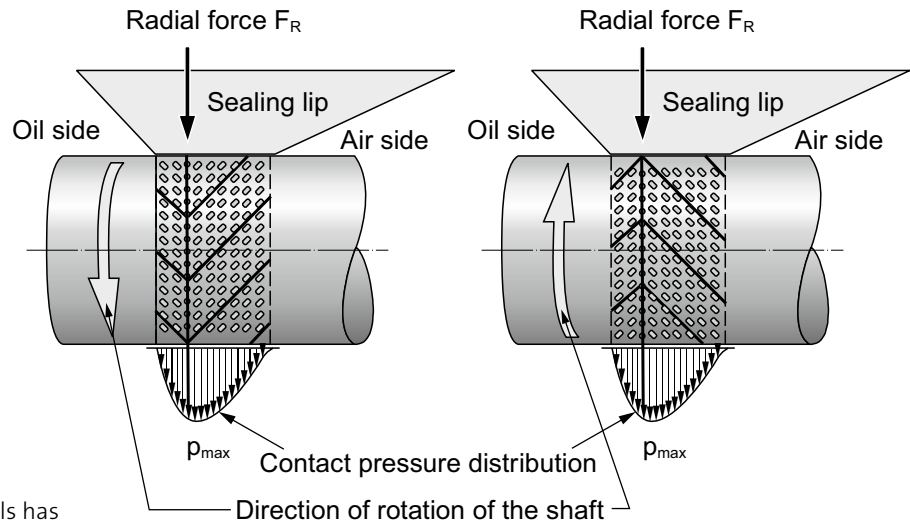
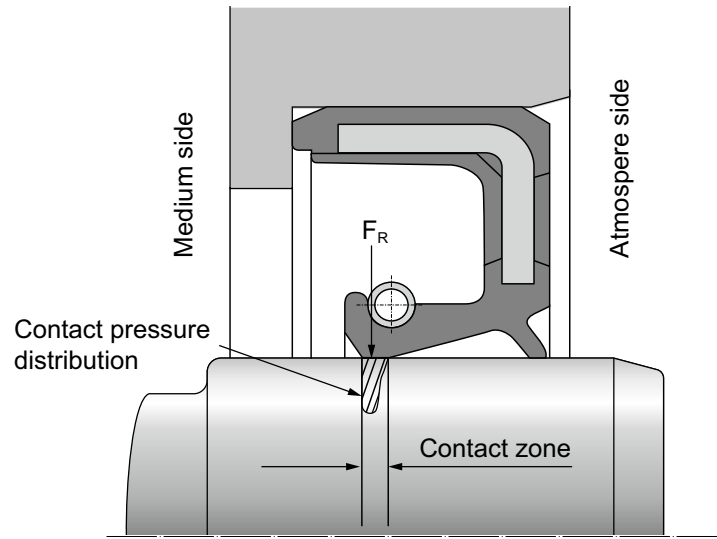

Each manufacturer of shaft seals has developed their own sealing lip design, however it is based on these general principles

In addition to the geometric design, it is important that the sealing lip and the shaft "run in" on each other in the contact area. This 'run in' convergence ensures that the contact area of the sealing lip is slightly roughened. This irregular structure of the contact area allows for sufficient fresh oil to flow under the sealing lip whilst also ensuring that the oil is returned. Ideally, this results in a permanent exchange of fresh oil under the sealing lip to help ensure a long service life.

SPECIAL APPLICATIONS

In reality, there are many deviations from the ideal operating conditions, such as the following:

- sealing under negative pressure or vacuum
- separation of two media
- sealing in case of very heavy dirt contamination (e.g. agriculture)
- insufficient lubrication

We can develop custom solutions for the listed scenarios and alternative unique applications.



OPERATING CONDITIONS

TEMPERATURE AND PRESSURE

Due to the rotation of the shaft and the resulting friction at the sealing edge, the actual temperature at the sealing edge is higher than in the oil bath.

$$t_D = t_{Oil} + t_O$$

t_D = Temperature at the sealing edge [°C]

t_{Oil} = Temperature in the oil bath [°C]

t_O = Overtemperature [°C]

This temperature difference between the oil bath and the sealing edge is called overtemperature. The level of the overtemperature depends on the following parameters:

- circumferential speed/rotational speed
- lubrication condition/oil level
- heat dissipation
- pressure load
- design of the radial shaft seal
- surface condition of the shaft
- material of the radial shaft seal
- medium

With increasing circumferential speeds, the excess temperature at the sealing edge also increases. Depending on the circumferential speed, the overtemperature can be as high as +40 °C. If the maximum permissible operating temperatures for the elastomer material used are exceeded, this will lead to premature hardening of the elastomer material and severe wear. For the permissible operating temperatures of our elastomer materials, please refer to the tables in the Materials chapter or our website. The high temperatures listed in the tables refer to the temperature at the sealing edge.

PRESSURELESS OPERATION

Radial shaft seals are generally designed for pressureless operation, whereby pressures of up to 0.5 bar can be sealed, depending on the respective operating conditions (temperature, speed, medium to be sealed).

Reference values for the selection of materials for pressureless applications as a function of the maximum permissible circumferential speed are shown below.

To prevent overtemperatures that endanger the function at the sealing edge, which can lead to a hardening of the elastomer or the formation of oil carbon, the maximum permissible circumferential speed may not be exceeded.

The reference values listed are empirical values in accordance with DIN 3760. No manufacturer-specific properties of the radial shaft seals, such as the geometry of the sealing lip or radial force, are taken into consideration. These reference values apply only in the case of unpressurized operation, adequate lubrication conditions with mineral oil and good heat dissipation at the sealing point. In the event of insufficient lubrication or pure grease lubrication, the limit values should be reduced by half. The reference values should also be reduced in the event of pressurization, poor surface quality in the running area and large runout deviations. Higher circumferential speeds are permissible for shafts with larger diameters since heat dissipation is better.

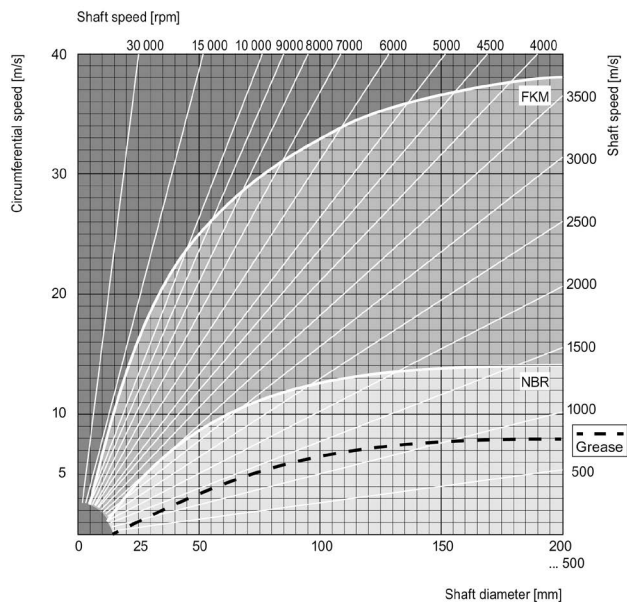

Limits for circumferential speed/speed depending on the diameter of the shaft and the material.

PRESSURIZATION FOR STANDARD MODELS

Standard radial shaft seals are designed for use at very low pressures of up to 0.5 bar. They seal spaces with small pressure differences against liquids, greases and air.

OPERATION WITH PRESSURIZATION

The existing operating conditions, pressure and circumferential speed, are decisive for the selection of the proper radial shaft seal. In the case of pressurized radial shaft seals, the sealing lip is pressed strongly against the shaft, which increases the radial force as a function of the pressure. However, this process also increases the thermal load and the frictional power at the sealing edge, which can lead to premature wear and hardening.

Back-up rings

Pressure differences in excess of 0.5 bar can also be sealed with standard radial shaft seals and an additional back-up ring (preferably made of POM). The maximum permissible pressures depend on the speed and the shaft diameter. In combination with a back-up ring, only designs without a protective lip can be used because the back-up ring supports the sealing lip under the diaphragm. For this reason, the back-up ring must be precisely adapted to the respective sealing lip profile. For each standard model (without a protective lip), the respective back-up ring drawing can be requested. A sealing system of this type is ideal where the WAY/WASY model that can withstand pressure is not available.

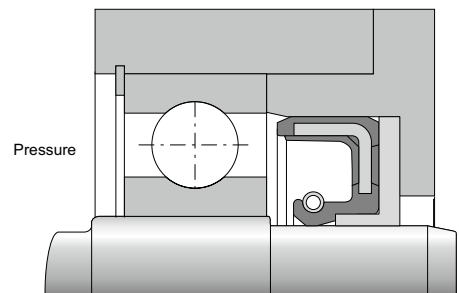

A shaft seal (WA) with an additional back-up ring.

WAY/WASY Design

The WAY/WASY model is recommended for pressure differences in excess of 0.5 bar, pulsating pressures and vacuum applications. Compared to the standard version (WA/WAS), the WAY/WASY model is characterized by a compact sealing lip profile. Due to its short and reinforced sealing lip, this design is less sensitive to pressure loads.

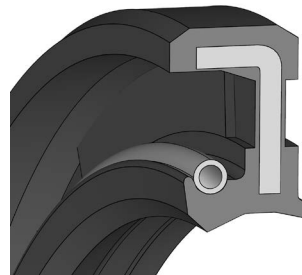

MEDIA TO BE SEALED

The selection of the right radial shaft seal, in particular the right material, depends not only on the circumferential speed of the shaft, the pressure load and the friction-related temperature increase, but also on the medium to be sealed and its temperature. In particular, the chemical resistance of the radial shaft seal to the medium used has a significant influence on the service life of the seal.

Chemical attack of the medium can lead to

- softening of the material by swelling
- hardening and premature aging phenomena which are accelerated in high temperature environments.

Thanks to decades of experience, the behavior of the individual material groups against a wide range of media can be easily determined using the resistance tools from Freudenberg Sealing Technologies. We recommend performing a storage test in advance when using new media, or in the event of ambiguities, or if the maximum operational limits are applied simultaneously (e.g. temperature, pressure, circumferential speed). For cases in which there are higher requirements for media resistance, we would recommend either the WCP20 model which has a PTFE sealing lip or the WEPO design which is made entirely of PTFE.

FREQUENTLY USED MEDIA

Mineral oil-based oils and greases

As a general rule, NBR and FKM standard materials have a good resistance to mineral oils and greases. Therefore testing is recommended only when media with a high additive content is used, for which no empirical values are available.

Synthetic oils and greases

The structure of synthetic lubricants is essentially characterized by the base oil and many different additives. Depending on the type of base oil and additives, the standard NBR material can be used for low additive lubricants. For higher additive oils, especially at temperatures above +80 °C, FKM is better suited as a sealing material. However, resistance problems may occur due to the large number and combination of additives in synthetic lubricants. We therefore recommend verifying the suitability of the material in advance by performing a test.

Further information on the areas of application and resistance of radial shaft seals and the materials used can be found in our Resistance Guide.



Resistance
Tools



INSTALLATION SPACE AND CONSTRUCTIVE RECOMMENDATIONS

ABOUT THE SHAFT

THE SHAFT

The shaft is an essential element in the rotary sealing system and must therefore fulfill a number of technical requirements to ensure a good sealing effect. The proper design of the shaft in the running surface area of the sealing edge of the radial shaft seal is critical for the service life and sealing function.

TOLERANCES

For the shaft diameter d_1 , within the running surface area of the sealing edge of the rotary shaft seal, it is necessary to apply the ISO tolerance field h11 according to DIN ISO 286 in order to achieve sufficient overlap of the sealing lip. For the shaft roundness, tolerance class IT 8 is required.

SURFACE FINISH OF THE SHAFT

The surface roughness, measured in the longitudinal direction, should be within the following ranges:

- $R_z = 1.0$ to $4.0 \mu\text{m}$
- $R_{\text{max}} \leq 6.3 \mu\text{m}$

Excessively smooth shaft surfaces in conjunction with high circumferential speeds lead to malfunctions. The lubricant supply to the sealing edge is disrupted, the hydrodynamic lubricant film under the sealing edge breaks off and this leads to thermal damage to the sealing edge.

Excessively rough shaft surfaces lead to premature wear of the sealing edge. Both above scenarios would be suboptimal and result in severe leakage.

SURFACE HARDNESS OF THE SHAFT

The service life of the sealing edge also depends on the surface hardness of the shaft which should be at least 45 HRC. In the case of ingress of contaminants or dirt from outside, as well as at circumferential speeds $\geq 4 \text{ m/s}$, the surface hardness should be at least 55 HRC - 60 HRC. For surface hardening, a hardening depth of at least 0.3 mm is required. Chrome-plated, cadmium-plated, nitrided and phosphatized shaft surfaces are possible custom treatments and their suitability must be evaluated on a case-by-case basis.

PREPARATION OF THE SHAFT SURFACE

The shaft must be machined free of twists in the running surface area of the sealing edge so that no conveying or pumping effect and thus no leakage occurs at the sealing point. Correct machining of the running surface is vital for the sealing function.

The most frequently utilised method is plunge grinding (grinding without axial feed of the grinding wheel), as this produces a completely twist-free mating surface. To achieve a high degree of safety, the firing time must be 30 seconds. The grinding wheel should be dressed with a multi-point dresser to prevent twist from occurring. When grinding, a gear ratio between the rotational speed of the shaft (e.g. 50rpm) and the rotational speed of the grinding wheel (e.g. 1500rpm) should be avoided.

Other machining processes, such as hard turning and smooth-rolling, are specialized processes that are only suitable for a limited number of applications.

RUNOUT

Runout, or dynamic eccentricity, of the shaft must be avoided as far as possible and must not exceed certain limits depending on the shaft speed. When operating at high rotational speeds, there is a risk that the sealing lip can no longer follow the shaft due to its inertia. This can create an excessively large gap between the sealing edge and the shaft, allowing the medium to escape and leak out.

It is therefore advisable to position the radial shaft seal in the immediate vicinity of the bearing and to keep the clearance of the bearing as small as possible. The permissible values for the runout deviation as a function of shaft speed are shown in the diagram below. Restricted values apply to WAY/WASY models, as the sealing lip is designed to be considerably stiffer due to the higher operating pressure.

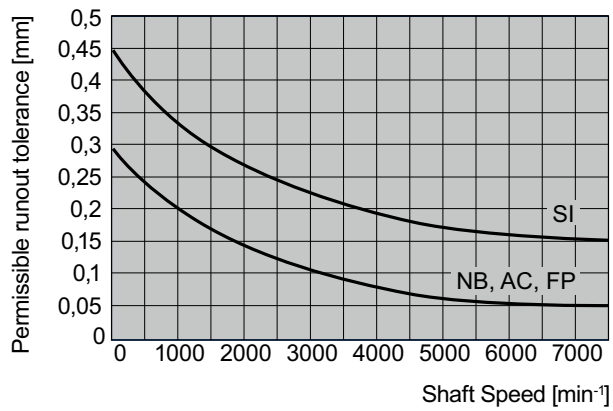

Permissible runout tolerance of the shaft

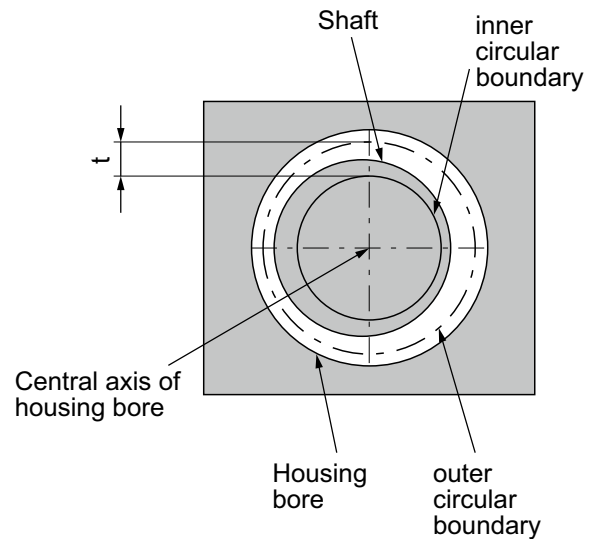

Illustration of the runout tolerance

CHAMFER ON THE SHAFT

In order to prevent the sealing lip from being damaged or deforming during installation, the following two design recommendations for the shaft shoulder should be implemented:

Mounting direction Z of the shaft:

Round off the shaft shoulder with $r1 = 0.6$ to 1 mm.

Mounting direction Y of the shaft:

Chamfering of the shaft shoulder, recommended angle 15° to 25° . The chamfering diameter d_3 is listed in the adjacent table.

MOUNTING BEVEL

d_1 [mm]	d_3 [mm]
< 10	$d_1 - 1.5$
10 < 20	$d_1 - 2$
20 < 30	$d_1 - 2.5$
30 < 40	$d_1 - 3$
40 < 50	$d_1 - 3.5$
50 < 70	$d_1 - 4$
70 < 95	$d_1 - 4.5$
95 < 130	$d_1 - 5.5$
130 < 240	$d_1 - 7$
240 < 500	$d_1 - 11$

DAMAGE TO THE SHAFT

All types of damage, such as scoring, scratches, bumps, shrinkage cavities, pores and corrosion on the running surface of the shaft must be avoided at all costs as they can lead to premature failure and leakage. 30 percent of leakages are caused by incorrect shaft machining or damage, therefore it is vital that shafts are protected from production to final assembly. Transport devices or special molded or slide-on protective plastic covers can be used.

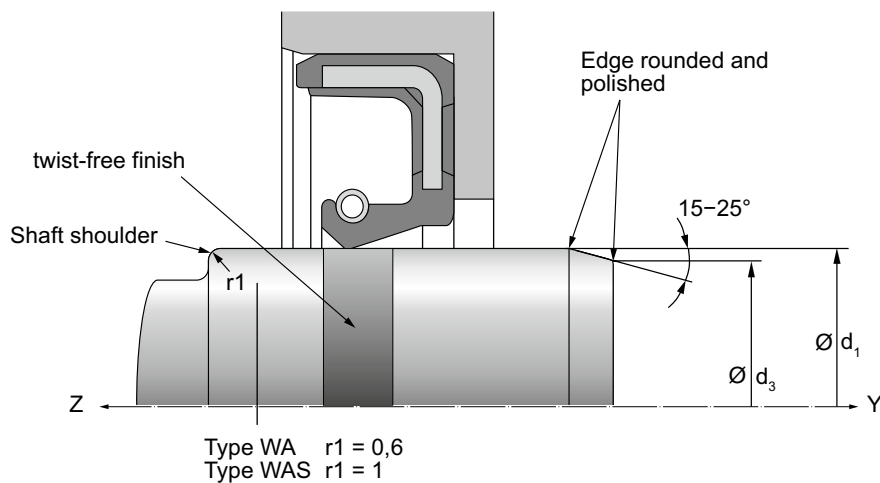

HOUSING BORE

The design of the housing bore is important in order to achieve a secure and tight fit in the housing bore. The following technical requirements must be observed:

TOLERANCES

For the bore diameter d_2 the tolerance class ISO H8 must be applied, in conjunction with the standardised design of the radial shaft seal, in order to achieve a reliable static sealing effect.

SURFACE FINISH OF THE HOUSING BORE

permissible values for model WA

$R_z = 10$ to $20 \mu\text{m}$
 $R_{\text{max}} \leq 25 \mu\text{m}$

permissible values for models WB, WC

$R_z = 6.3$ to $16 \mu\text{m}$
 $R_{\text{max}} \leq 16 \mu\text{m}$

In the case of radial shaft seals with a metallic outer casing and/or use in conjunction with low-viscosity media or gas, very good surface quality is necessary, i.e. the surface in the housing bore should be free from damage and machining marks of all kinds, e.g. scratches, scores, cavities and impact points.

HOUSING DIMENSION

The following table shows the recommended housing dimensions based on the radial shaft seal height b :

b [mm]	t_1 min. [mm]	t_2 min. [mm]	r_2 [mm]
7	5.95	7.3	0.5
8	6.8	8.3	0.5
10	8.5	10.3	0.5
12	10.3	12.3	0.7
15	12.75	15.3	0,7
20	17	20.3	0.7

CHAMFER ON THE HOUSING BORE

The housing bore should have a chamfer of $10 - 20^\circ$ and the transitions should be made without burrs to allow for trouble-free installation of the radial shaft seal.

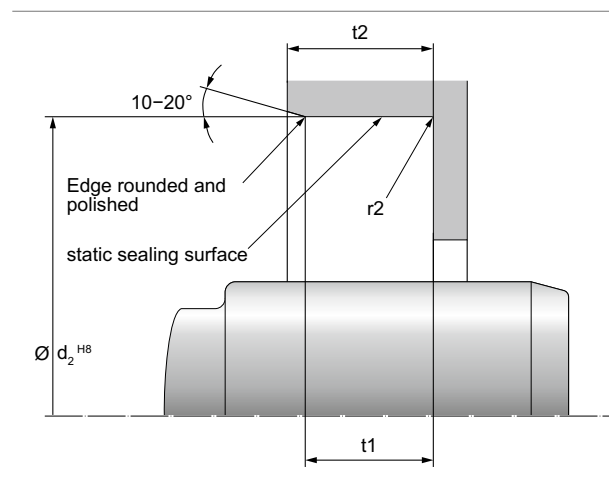

COAXIALITY TOLERANCE OF THE HOUSING BORE

The permissible coaxiality tolerance T_m between the housing bore and the shaft is shown in the graph below. Eccentricity between the central axis of the shaft and the housing bore can lead to leakage due to either uneven stress on the sealing lip accelerating the rate of wear, or at the other extreme, insufficient contact pressure between the sealing lip and the shaft.

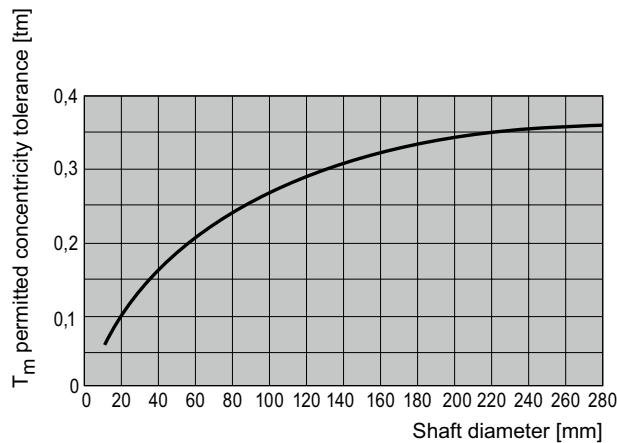

Permissible coaxiality tolerances of the shaft to the housing bore

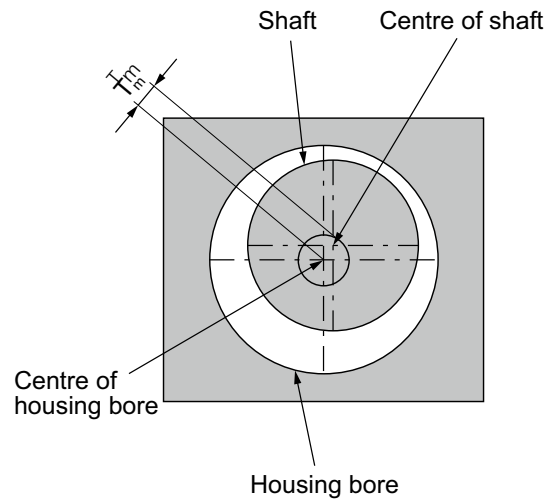

Illustration of the coaxiality tolerances

PERMISSIBLE SKEW

The installed radial shaft seal must be installed as centrally as possible and perpendicular to the shaft. The straightness tolerance according to DIN 3761 should not exceed the values in the adjacent table. Larger deviations (misalignment) lead to uneven wear of the sealing lip and have a negative effect on the sealing result.

HOUSING DESIGN

When installing rotary shaft seals in complex housings there is a risk that they will be severely deformed and/or expanded which can lead to displacement of the shaft seal or to leakage. For such cases, it is recommended to use rotary shaft seals with an elastomer outer covering (e.g. WA) and, on request, we also offer the version with a grooved elastomer outer covering (e.g. WAK).

In the case of split housings, attention must be paid to the design of the edges of the housing to avoid damage to the shaft seal or leakage. We recommend designs with an elastomer outer covering for split housings.

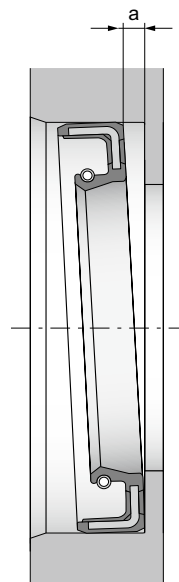

Shaft diameter [mm]	Maximum perpendicular deviation [mm]
up to 25	0.1
over 25 to 80	0.2
over 80	0.3

Representation of the skew



INSTALLATION

Approximately 30 percent of all failures and damage to radial shaft seals can be attributed to incorrect installation or unsuitable installation aids. We therefore recommend that radial shaft seals be installed in accordance with DIN 3760.

Accordingly, the installation space and radial shaft seal should be carefully cleaned before installation otherwise dirt particles adhering to the seal or installation space could lead to leakage shortly after the start of operation. We would recommend the use of hydraulic or mechanical press-in tools to transport the radial shaft seal into the housing bore. These tools act upon a large area on the outer surface of the radial shaft seal and ensure that the pressing force is applied as close as possible to the outside diameter which minimizes skewing of the radial shaft seal. The press-in tool should be held in the final position for a while in order to inhibit springback of the rotary shaft seal and reduce skewing. Mounting sleeves must be used when the radial shaft seal has to be guided over sharp-edged surfaces, e.g. grooves, threads or shaft ends and the sleeve must not have any damage such as scratches or rough surfaces. For a tight fit, it is important to ensure that the outer sleeve is fully pressed into the housing bore otherwise there is a risk of the radial shaft seal migrating out of the housing bore.

DIFFERENT INSTALLATION AIDS FOR RADIAL SHAFT SEALS

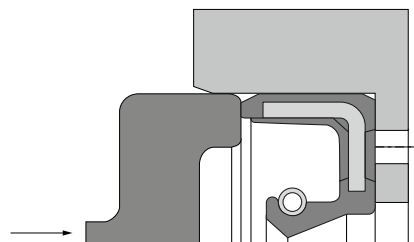
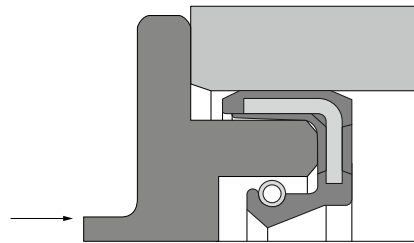
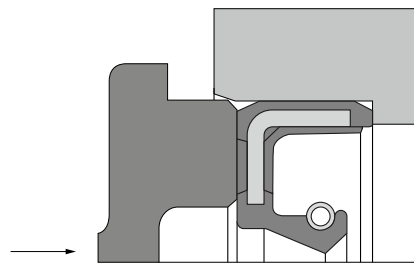
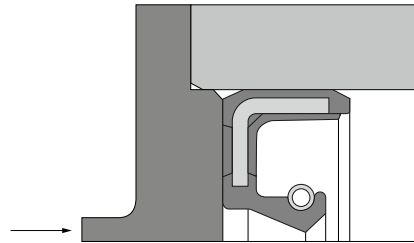

If the gap between the protective lip and the sealing lip is filled with grease, the following should be observed:

- max. grease filling of the gap 30 – 40%
- apply grease with a wooden or metal spatula (not with a brush)
- keep the sealing lip free from grease
- suggested grease: Klüber Petamo GHY 133 N

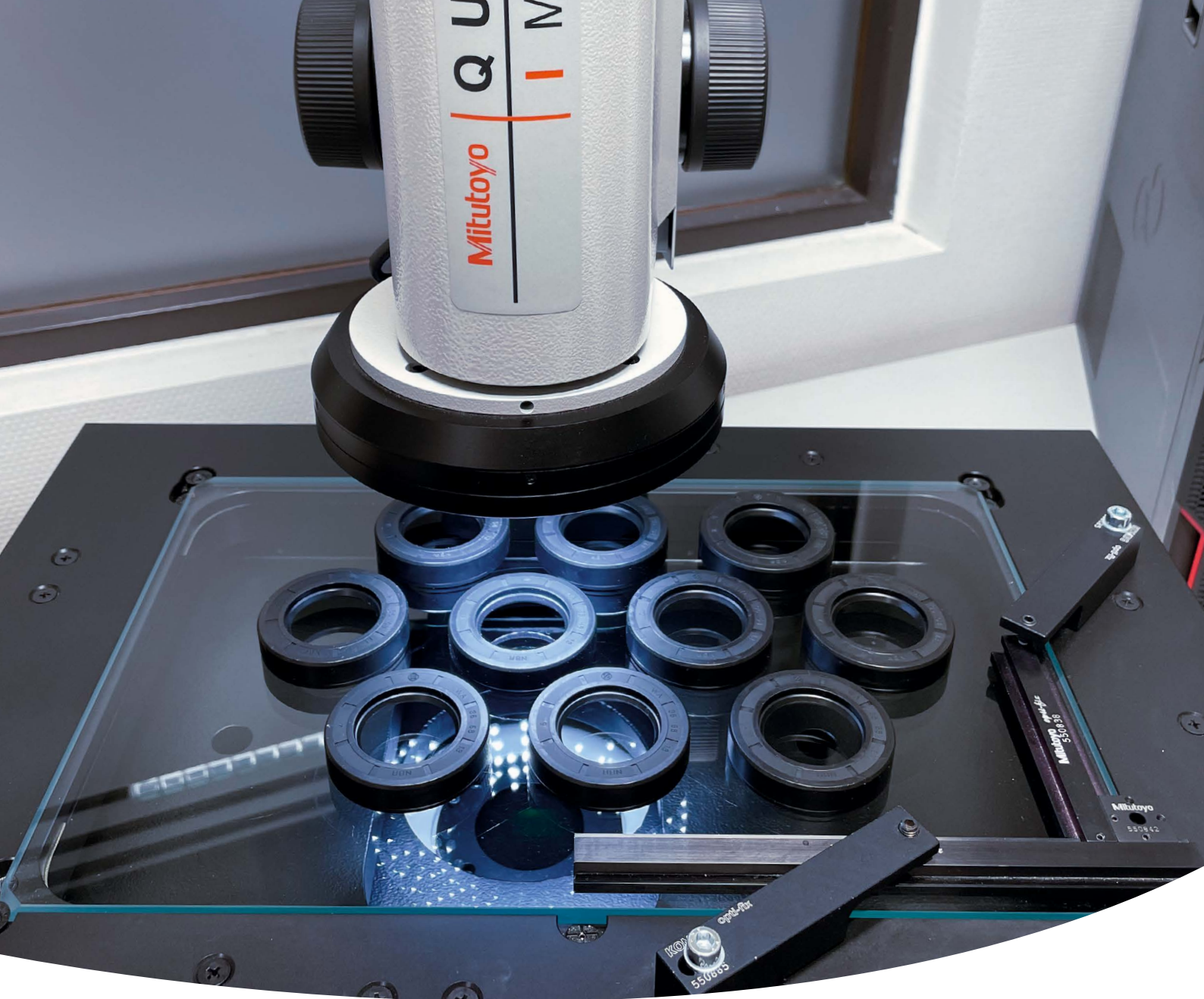

QUALITY ASSURANCE

For Dichtomatik brand products, we actively strive for “zero defect target” product quality by working closely with our customers and production. Our batch print tracking allows us to trace every step in the supply chain and to provide

information on the product characteristics and ingredients. Batch information is provided on the product labels as well as on the corresponding delivery bills.

DIMENSIONAL TESTING

A wide range of measuring equipment and instruments are available for the dimensional inspection of radial shaft seals, usually for the measurement of inner and outer diameters as well as height. These include optical measuring machines and measuring microscopes, calipers, depth gauges, circumferential measuring tapes and many more. The measurement of the inner diameter of the sealing edge and/or the protective lip is preferably carried out with the help of non-contact optical measuring machines and measuring microscopes. For larger dimensions, and depending on the material and the design, calipers or inside circumference measuring tapes are also used. Profile cross-sections (drawing views) can be tested destructively. For this purpose, sections of the RWDR are cast in resin, cut to size and the surface to be measured is leveled. Testing and measurement are then generally carried out using non-contact optical measuring machines and measuring microscopes.



Dimensional inspection of a radial shaft seal using a measuring microscope



Profile cross-section inspection of a radial shaft seal

RADIAL FORCE MEASUREMENT

The radial force is measured using the two-jaw measuring method in accordance with DIN 3761-9. The radial force is the sum of the force components of the sealing lip of a radial shaft seal acting perpendicularly on the parting plane of the measuring jaws to the selected shaft diameter. Corresponding measuring jaws are available for the usual standard dimensions.

SHAPE AND SURFACE TESTING

The quality specifications for radial shaft seals are based on DIN 3761. Additional requirements can be agreed upon as a basis for delivery when the order is placed. Monitoring of compliance with the quality specifications is carried out by using magnifying lamps and digital microscopes.



Radial force measurement of a radial shaft seal



Surface inspection of a radial shaft seal using an electronic microscope



SHAFT REPAIR SLEEVES

WSH-R

The shaft repair sleeve WSH-R is part of our standard portfolio.

DESCRIPTION

Product group:	WSH shaft repair sleeve
Design:	R Repair
Material:	stainless and acid-resistant steel 1.4301 (AISI 304)

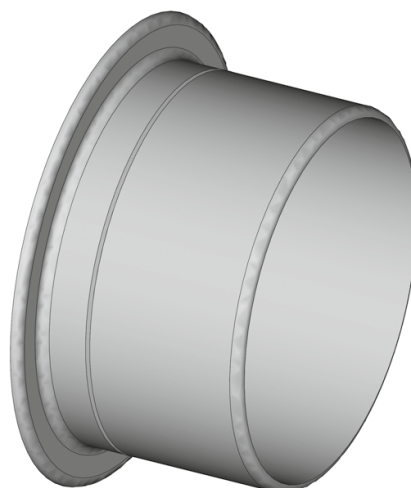

OPERATING LIMITS

The operating limits, such as the temperature, circumferential speed and pressure, are specified by the radial shaft seal chosen. The WSH-R generally covers the operating conditions for all common radial shaft seals.

TECHNICAL DATA

The following technical requirements must be met by shaft repair sleeves:

Surface finish/ roughness values:	Rz = 1 to 5 μm Rmax \leq 6.3 μm
Machining of the surface:	twist-free ground
Surface hardness:	HV 220 (95 HRB) wear-resistant machined
Wall thickness:	0.28 mm thin-walled version

APPLICATION

WSH-R shaft repair sleeves are used to repair worn-in or worn running surfaces of radial shaft seals on shafts, e.g. in drive technology. They offer a cost-effective alternative to replacement or costly reworking of the worn shaft and are easy to install. Reworking the damaged shaft may lead to a significant reduction in the original diameter resulting in an incompatibility with the existing WDR inner diameter. This problem can be easily rectified by using a WSH-R for which dismantling of the shaft is not required and the ensuing costly rework is also avoided.

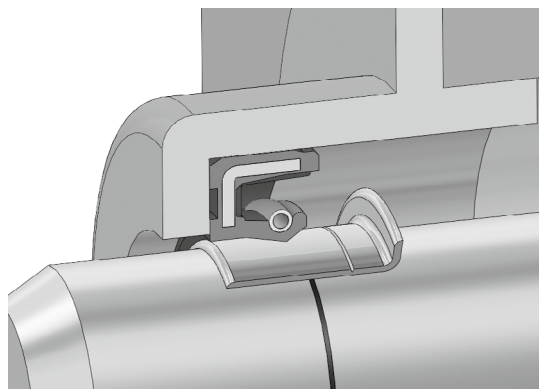

Shaft repair sleeves in operation between the radial shaft seal and the shaft

FUNCTION AND ADVANTAGES

By using the WSH-R in case of repair, proper function can be restored quickly and permanently.

WSH-R shaft repair sleeves offer the user the following advantages:

- simple and quick repair, the mounting sleeve is included in the delivery
- less costly restoration of the running surface on the shaft, as the shaft does not need to be dismantled and reworked
- elimination of costly machine downtime, as repairs are reduced to a minimum. The running surface of the radial shaft seal is permanently and fully functionally restored
- secure fit on the shaft due to the interference fit
- retention of the original seal dimension

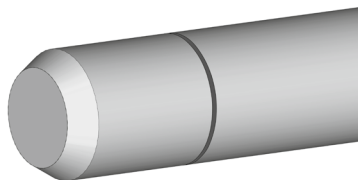

Shaft with an inlet track

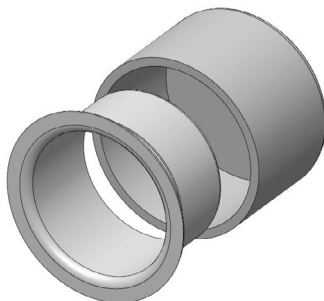

Mounting sleeve with a shaft repair sleeve

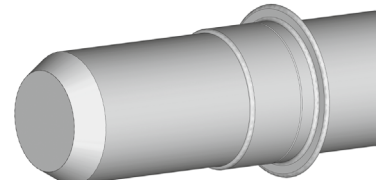

Shaft repair sleeve on the shaft

INSTALLATION INSTRUCTIONS

1. Clean the surface of the worn shaft and remove any burrs. Run-in marks, notches, grooves or noticeable roughnesses must be evened out using an appropriate epoxy filler compound
2. The shaft sleeve should be selected based on the shaft diameter d_1
3. For easier installation, lightly grease the surface of the shaft before you start
4. Place the WSH-R with the flange side on the shaft
5. Slide the mounting sleeve over the WSH-R. The mounting dimension Z can be achieved using the mounting sleeve supplied. If the mounting sleeve is too short, a tube with a similar diameter can also be used
6. Apply light hammer blows to the mounting sleeve (or use a pressing device) to push the WSH onto the worn area
7. If the mounting flange interferes with the function of the RWDR or the unit, it can be easily removed at the predetermined breaking point provided for this purpose
 - a) After mounting the WSH-R, cut the flange with a side cutter up to the predetermined breaking point and snap it off at the visible line (breaking point)
 - b) In difficult cases, e.g. when there is little installation space, it may be necessary to cut the flange already before assembly
8. Check the surface of the shaft again for burrs after assembly
9. Degrease the WSH-R before installing the seal
10. Install the radial shaft seal

The shaft repair sleeves are available from stock for diameter ranges between 12 and 200 mm. We also offer shaft repair sleeves up to 370 mm and thicker wall thicknesses however longer delivery times are required.

All standard articles, including availabilities and prices, can be viewed on our online ordering platform EASY. Additional dimensions can be manufactured upon inquiry.

The technical data in this catalogue is derived from standards, experience and repeated quality assurance tests and the listed values are to be regarded as general and non-binding. Exceeding and falling below the range boundaries may be possible. We therefore recommend that application cases in which maximum values could be reached should be discussed and coordinated with our technical department.

No changes to the catalog details will be announced. Previous editions lose their validity when a new edition of the catalog is published.

Reproduction of this brochure in any form requires the express permission of Freudenberg FST GmbH.

INDUSTRY PROVEN



COMPREHENSIVE PRODUCT PORTFOLIO FOR SEALING APPLICATIONS

Freudenberg Sealing Technologies has a broad, customer-oriented product portfolio of premium Freudenberg brand products for all applications – from customized individual solutions to complete sealing packages.

In addition, Dichtomatik brand products are ideal for several moderately demanding applications in general industry. The wide range of products is characterized by a very good price-performance ratio. Manufactured by certified external suppliers, the sealing products and solutions reliably meet

common industrial market quality standards. Additional services such as general technical support round off the range.

Freudenberg Sealing Technologies serves the entire sealing market with this complementary product portfolio and thus meets all market requirements – quickly, reliably and from a single source.

www.fst.com | dichtomatik.fst.com



Editorial information

Freudenberg FST GmbH

Höhnerweg 2-4
69469 Weinheim, Germany

Published by

Freudenberg Industrial Services GmbH

Albert-Schweitzer-Ring 1
22045 Hamburg, Germany
Tel. +49 40 669 89 0
fis.hamburg@fst.com
www.fst.com | dichtomatik.fst.com

Publication date

March 2024